

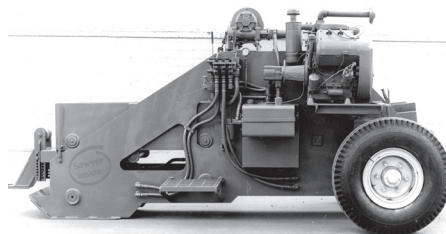

SAWYER

MFG COMPANY

CELEBRATING 65 YEARS

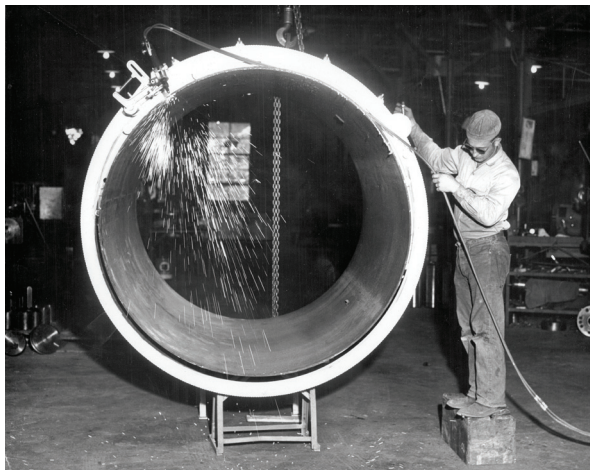
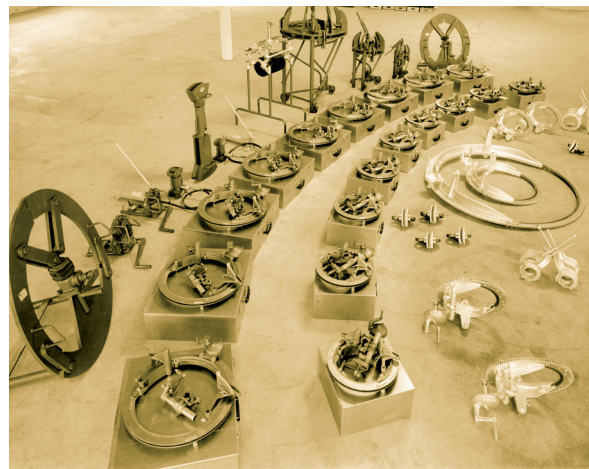

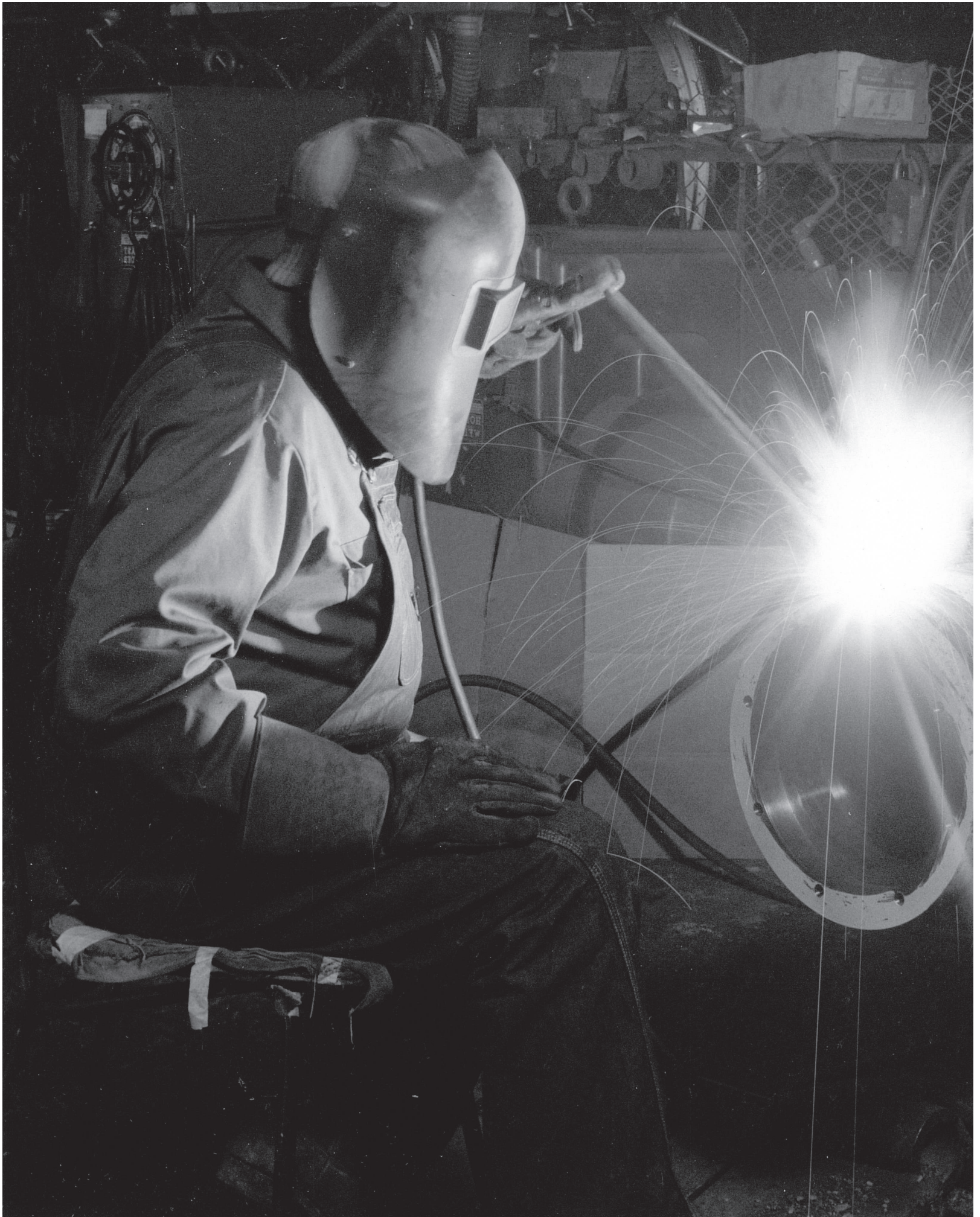

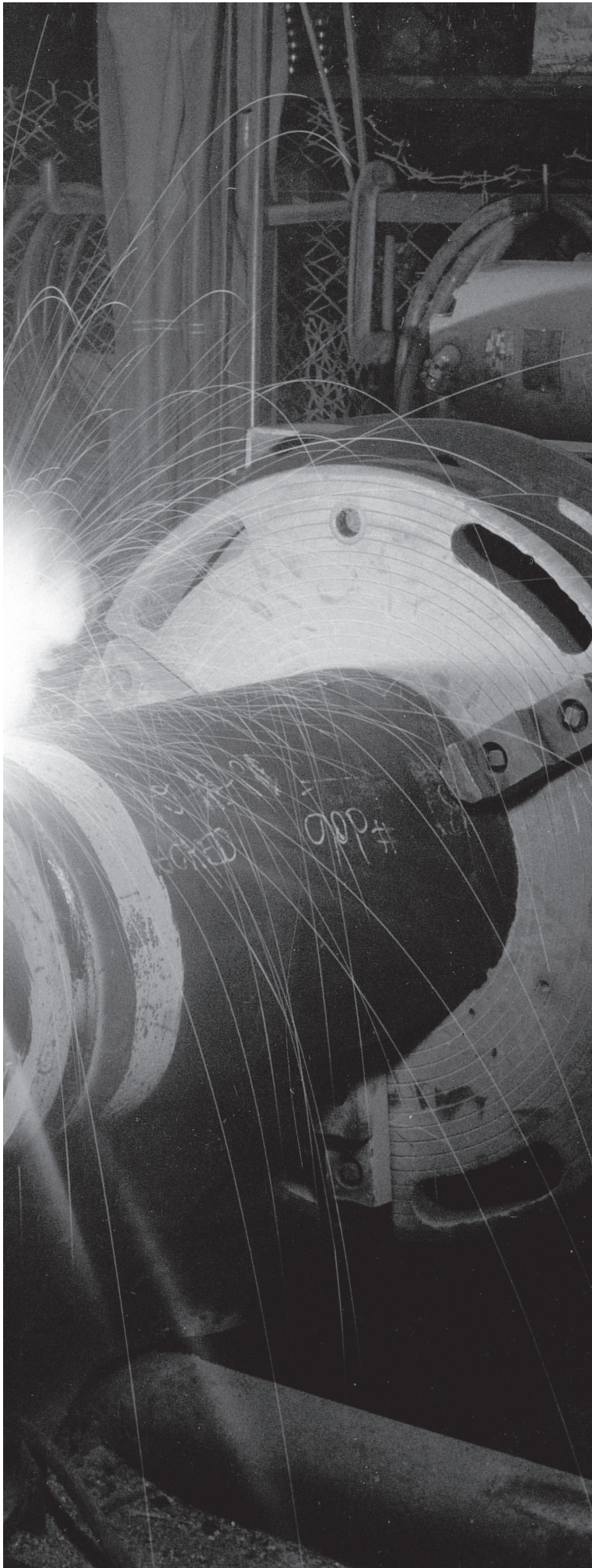

Beveling Equipment



Clamps - Internal



Clamps - External



Auxiliary Equipment



Pipe Lifting



Welding Tools



Weld Testing



Pipe Bending



BEVELING EQUIPMENT



On Band Type Beveling Machine:
"That band is smooth, not like that track torch."
-Edgar, Welder TX

“Band-Type” Beveling Machines

For Beveling in Tight Spaces

- For pipe 6” & larger
- Adaptable to any beveling requirement
- Out-Of-Round pipe attachments unnecessary



Beveling Band*
Model 206D



Transmission*
Model 206A

OPTIONAL ACCESSORIES



**Adjustable
Torch Holder**
Prevent Blow Holes
Model 284D



Motorized Kit
*Fastest Beveling Motor
in the industry*
Model 206F

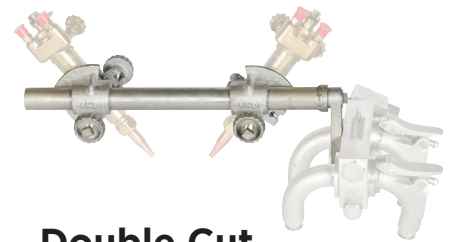

**Double Cut
Torch Holder**
*Save time with 2x the
cutting and beveling*
Model 283D



**Sturdy Galvanized
Carrying Case**
*Protect your
investment*
Model 13U



**Right Angle
Drive Kit**
*For the ultimate in
small clearance bell
holes*
Model 206E

* Band & Transmission sold separately
Torches shown for illustrative purposes only; available as optional equipment

“Quick Set” Pipe Cutting and Beveling Machines

Safe, Light and Simple

- Available for pipes sizes 1.5”–20”
- No spacers, dogs, or legs
- Lightest machine in the industry
- Adjustment arms provide simple and fast set up without spacers
- Made of cast aluminum for durable lightweight service



Quick Set*
Model 205CS

OPTIONAL ACCESSORIES



Adjustable Torch Holder

Prevent Blow Holes

Model 284C

Motorized Kit*

Fastest Beveling Motor in the industry

Model 205CES

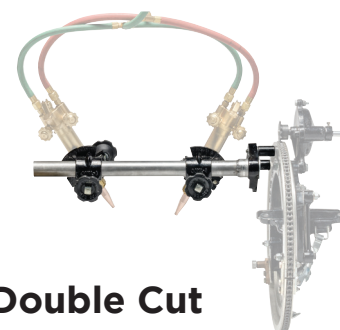

Double Cut Torch Holder*

Save time with 2x the cutting and beveling

Model 283B



Sturdy Galvanized Carrying Case

Protect your investment

Model 13K

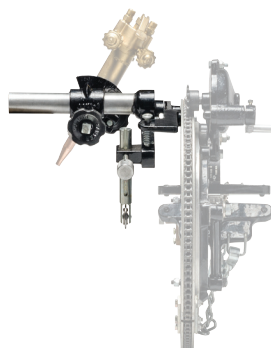

Out of Round Attachment*

Egged pipe... no problem

Model 281B

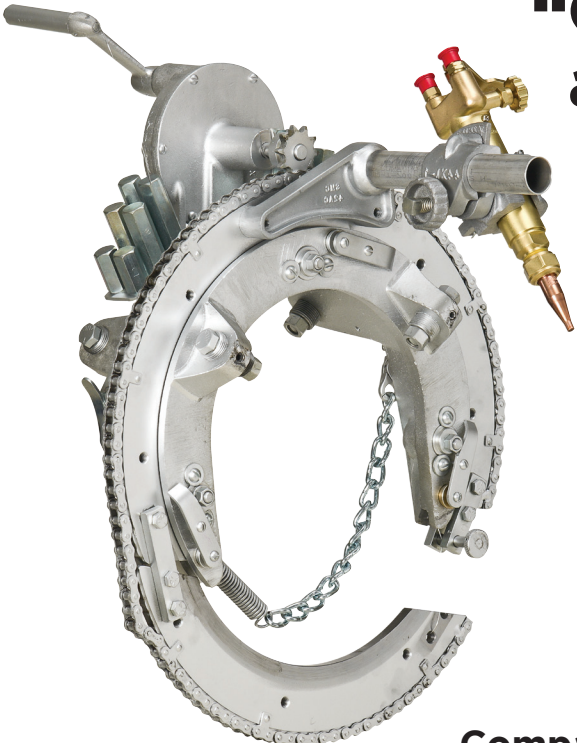

“Compact” Pipe Cutting and Beveling Machines

Built for the most demanding jobs

- Available for pipe sizes 3”–60”
- Fully enclosed gearbox keeps machine safe from damage
- Full traveling ring allows for smoother cutting and beveling

Compact*
Model 200C

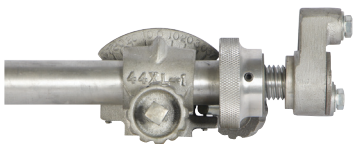

Adjustable Torch Holder

Prevent Blow Holes

Model 284B



Motorized Kit

Fastest Beveling Motor in the industry

Model 200CE

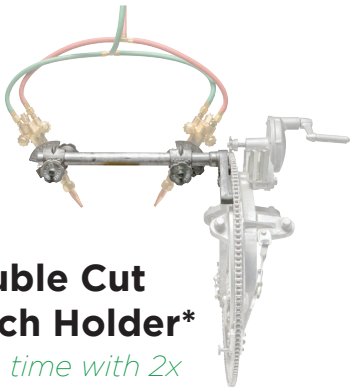

Double Cut Torch Holder*

Save time with 2x the cutting and beveling

Model 283A



Sturdy Galvanized Carrying Case

Protect your investment

Model 13Q

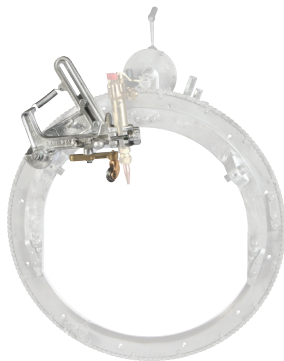

Out of Round Attachment*

Egged pipe...no problem

Model 281A



CLAMPS: INTERNAL



On Using Internal Line Up Clamps:
"In certain situations, my crew is faster than a crew with internal pneumatics."

-Allen WV



Model 256

Jack Screw Internal Line-Up Clamp

No Pipe is too big for this clamp

- Sizes 48" & up
- Easily holds & lines up large OD pipe
- Individual Jack Screws allow specific pressure application on a particular area while still aligning total pipe gap

Manual Internal Line-Up Clamp

A great solution for small pipe welding

- Available for 6" to 8" pipe OD sizes
- Stainless Steel, Copper, or Carbon Steel Shoes
- Optional Wheels: Hard or Soft
- Comes standard with 49' of Reach Rod Hook and Hand Crank

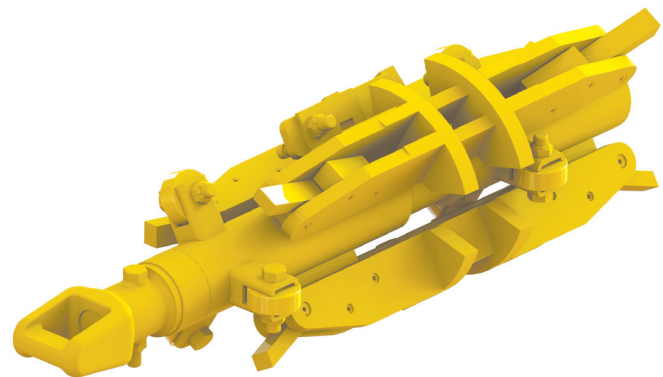

Model 242W

Manual Internal Line-Up Clamp

Fastest, most reliable clamp in the field

- Available in sizes 10" & up
- "Gap" is unobstructed for full stringer bead
- Available with copper backup ring
- Each clamp machined for specific pipe ID
- Comes standard with 49' of Reach Rod, Hook & Hand Crank

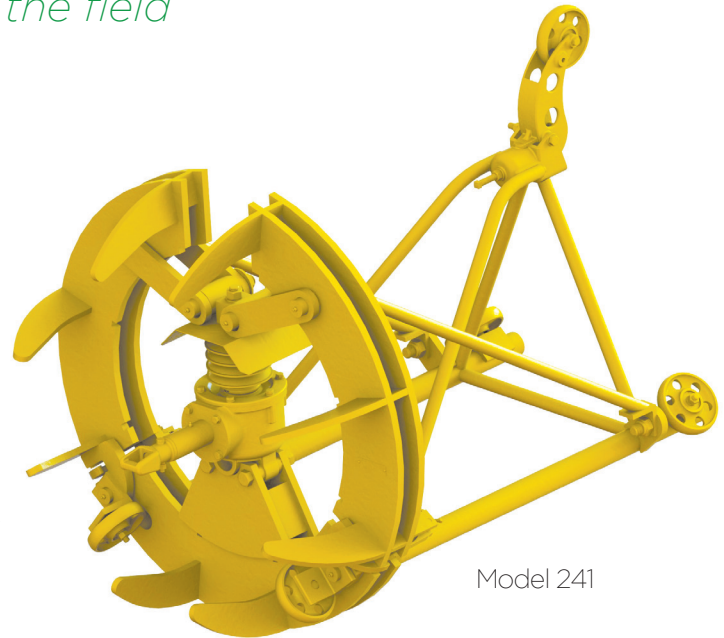

Model 241

Hydraulic Internal Line-Up Clamp

Has all the advantages of the manual plus hydraulic power

- Available in sizes 16" & up
- "Gap" is unobstructed for full stringer bead
- Requires no outside power unit
- Each clamp machined for specific pipe ID
- Comes standard with 49' of Reach Rod, Hook & Hand Crank

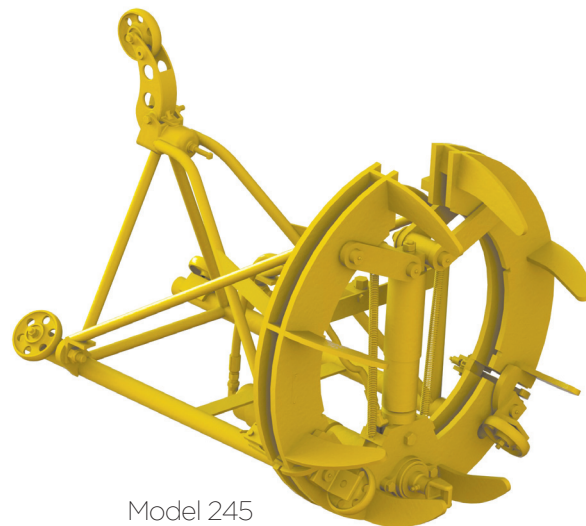

Model 245

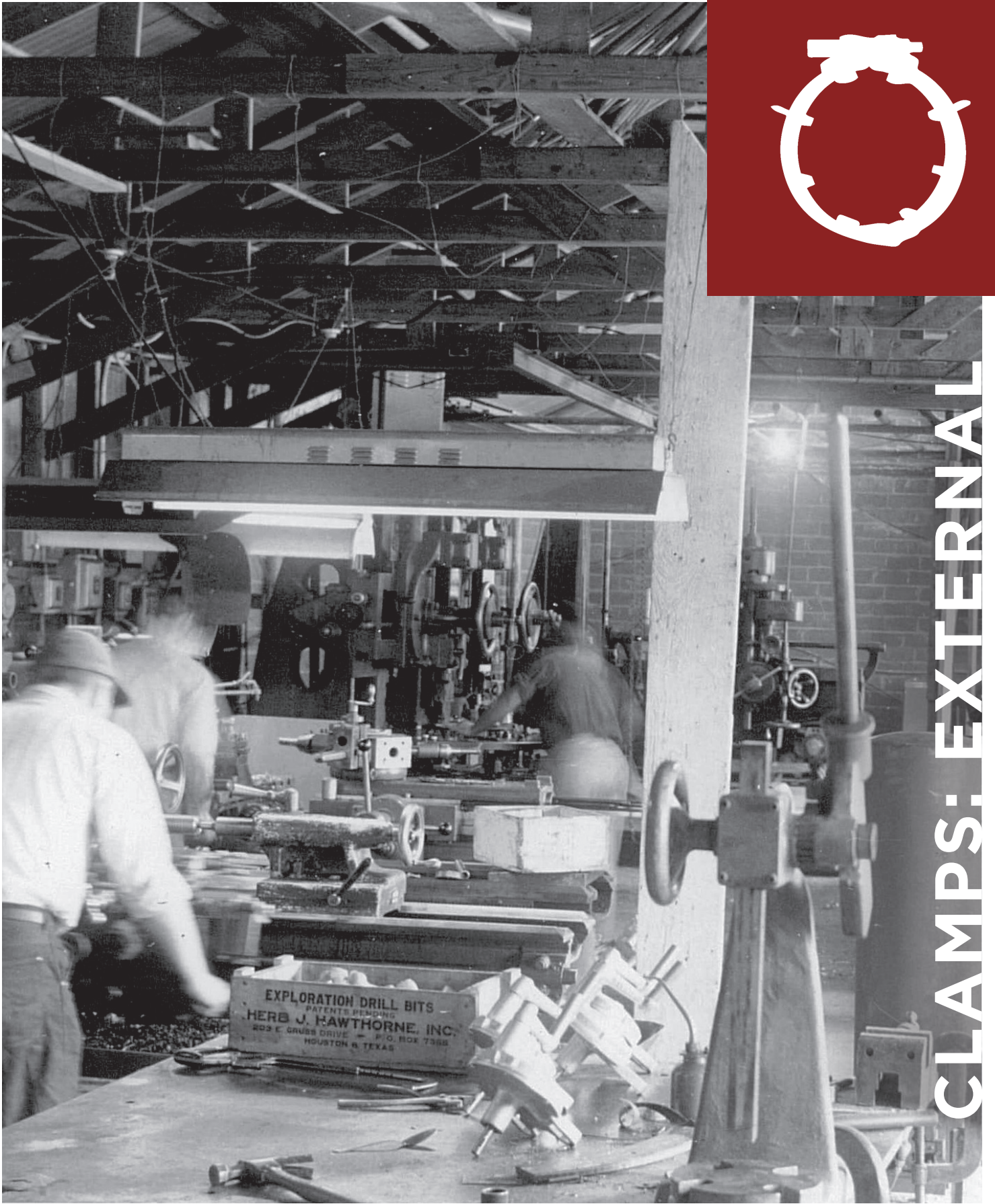

CLAMPS: EXTERNAL

On Using Aluminum Line Up Clamps:
"Farmers love these for maintaining pipe fence."
-Kent, Welding Distributor NM



Aluminum Line-Up Clamps

Welding Convenience for lining up pipe

- 3/4"—6" pipe
- Designed to permit full 360° welding
- Line bored to assure positive, accurate alignment
- High strength cast aluminum alloy
- Special tubing sizes available



Model 253

Hand Lever Cage Clamp

In service since 1930

- 2"—60" pipe
- Precision built for accurate alignment & long field life
- Available with stainless steel contact point



Model 125A

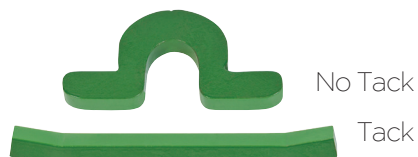



Model 125C

Hydraulic Cage Clamp

For those jobs that need a little more Umph

- 16"—60" pipe
- Hydraulic mechanism exerts extra pressure for aligning large pipe
- Available with Stainless Steel contact points

No Tack

Tack

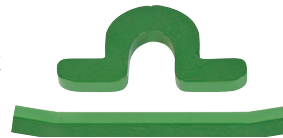

Ratchet Cage Clamp

Ease meets precision

- 6"—60" pipe
- Standard 1" ratchet wrench fits all sizes
- Operational mechanism is enclosed in protective housing to eliminate dirt contamination



Model 125E

No Tack

Tack

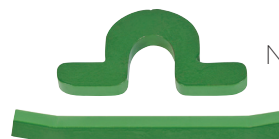

*Ratchet handle sold separately (part #125J)

EZ Clamps

Versatility without compromise

- From sizes 1"—12"
- Can be used on all materials including stainless
- Stainless Steel shoes and thumb screws included with each clamp
- Wing nut screws allow the clamp to adjust to specific pipe requirements (also known as "Hi-Lo")



Model 124

Chain Clamps

The MacGyver of external clamps

- From sizes 4" and up
- Safety permits elbows, tees, and other fittings to be held
- Reforms Schedule 40 pipe and aligns pipe up to Schedule 80
- Clamps color coded for quick identification (Red = Steel; Green = Stainless)

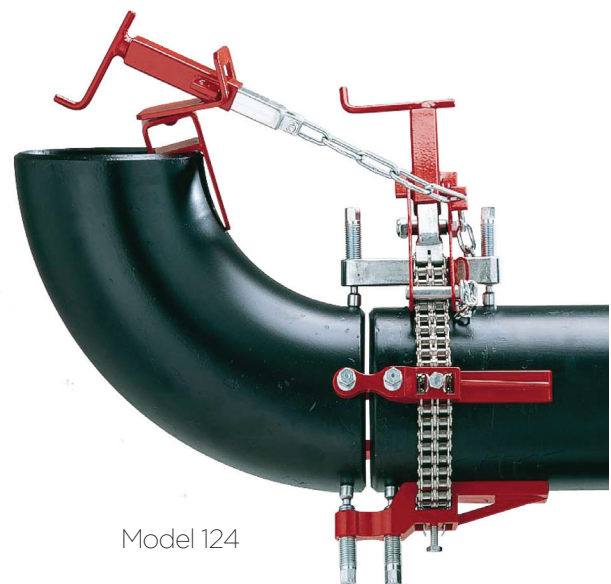

Model 124

External Ratchet Cage Clamp

Precision bored for perfect roundness and pipe sizing

- Standard sizes through 48"
- 10 ton ratchet pulls pipe into round



Model 255

Segmented Hydraulic Line Up Clamp

This clamp hasn't met a pipe too big

- Sizes 48" and up
- Double ring construction with relieved webs
- Hinged segments enhance flexibility and handling of large diameter pipe



Model 254

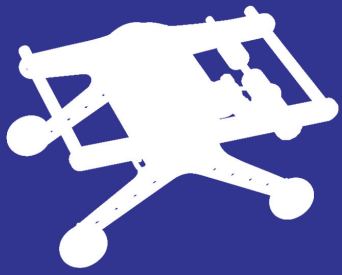

AUXILIARY EQUIPMENT



On Using Hydraulic Dent Removers:
"My dent remover has been around here for at least 40 years."
~Joell, OK

Accuwrap II

Hand held pipe wrapping machine



Model 229B

- 3 Available Sizes: For 2-18" Wide Tape Rolls
- Applies release liner or plain tape coatings
- Will accommodate tape with 1.5" or 3" diameter cores
- Ideal for spiral and cigarette wrapping
- Very low profile, requires less clearance

Pipe Expanders

The solution to egged pipe tie ins

- Sizes 10"—48"
- 90% of pipe is always in contact with shoes
- Gear box moves toggles to position shoes in true circle
- Acme screw exerts tremendous pressure to force pipe into round



Model 221



Model 224

Hydraulic Dent Removers

Reclaim Dented Pipe

- Sizes 10"—48"
- Shoe design concentrates pressure in exact dent area
- Complete with manual pump and 6' pressure hose



PIPE LIFTING



On Using Pipe Hooks:

“Having a safety factor of 8+ is unheard of in any industry.”

-Third party Metallurgical Test Lab

Pipe Hooks

Extra thick steel for longevity and greater safety

- Integrated handle for ease of use
- Increased safety due to reduced pinch points
- Interchangeable cast aluminum alloy inserts

Load Capacity (per hook)

A Size: 8,000 lbs
 B Size: 10,000 lbs
 C Size: 25,000 lbs



Model 232
 Sizes 3"—42"

Model 233
 Sizes 3"—42"



Model 231C
 Sizes 44"—72"



Model 125G

Pipe Tongs

Quickly String Pipe

- Sizes 2"—36"
- Equipped with grip pads that ensure a safe, positive engagement of the pipe and are field replaceable
- Designed to permit an automatic release of the pipe when lift line is slacked off

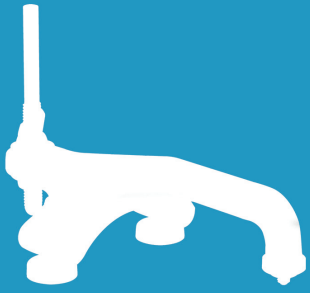

WELDING TOOLS

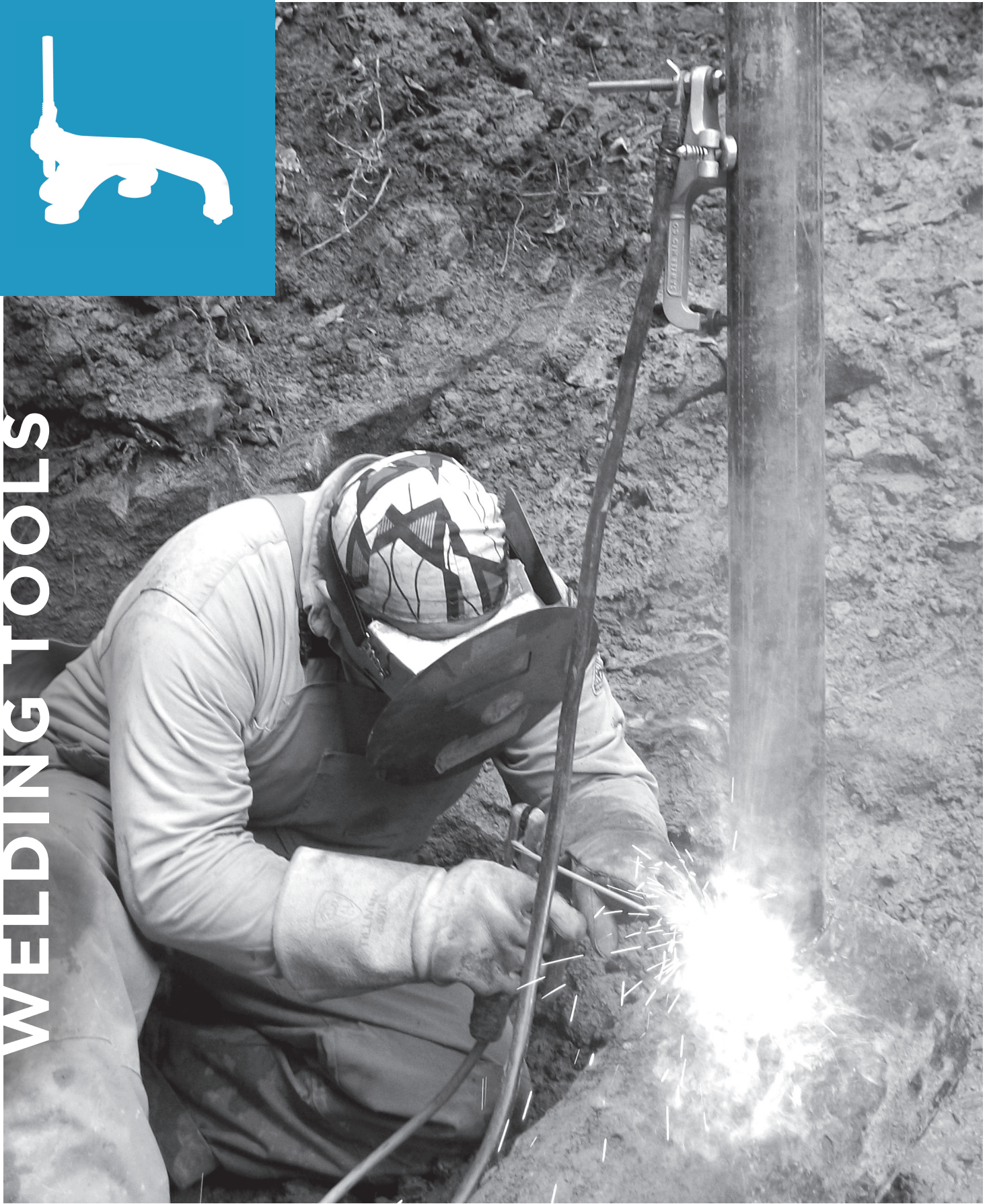

On using the Grasshopper:
"[As a result of] the user friendliness of the machine, production has gone up."

David S. Rig Welder North Dakota

Welding Grasshopper

The Grasshopper is the fastest, most dependable method of securing a ground

- Grounding Bolt has adequate length for two grounds, permitting brother-in-law welding
- Nylon-insulated magnets prevent arcing at contact point
- Ergonomical design for quick and simple placement and removal

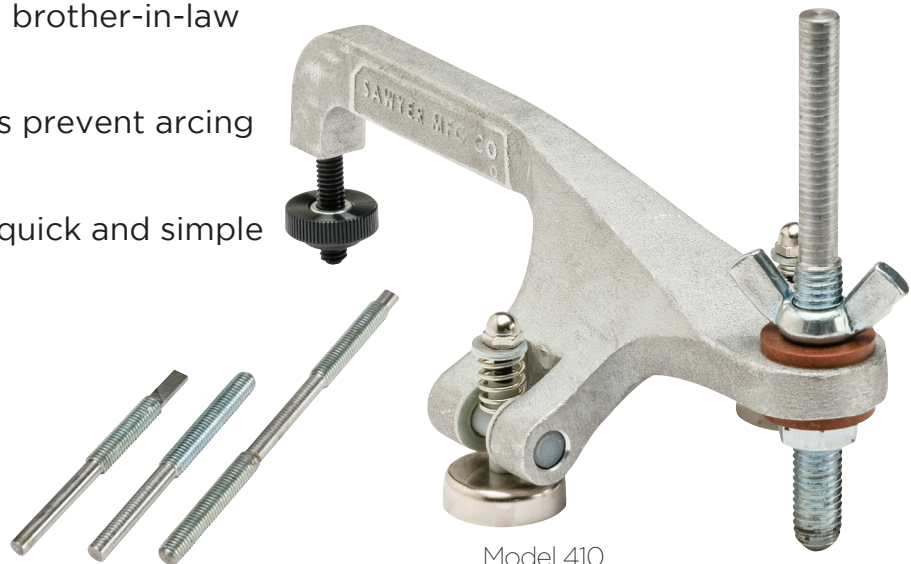

Model 410



Part 49B

Boomer

The go-to tie down for welding equipment

- For use with coupon cutters, all saddle beveling machines
- Great for Welding Bottle Tie downs
- Pipeline Proven
- Available with additional chain to accommodate any size job

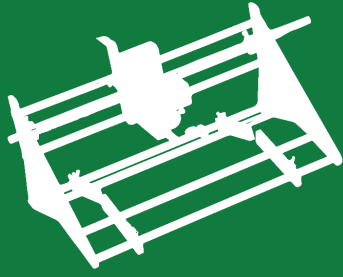

WELDING TESTING

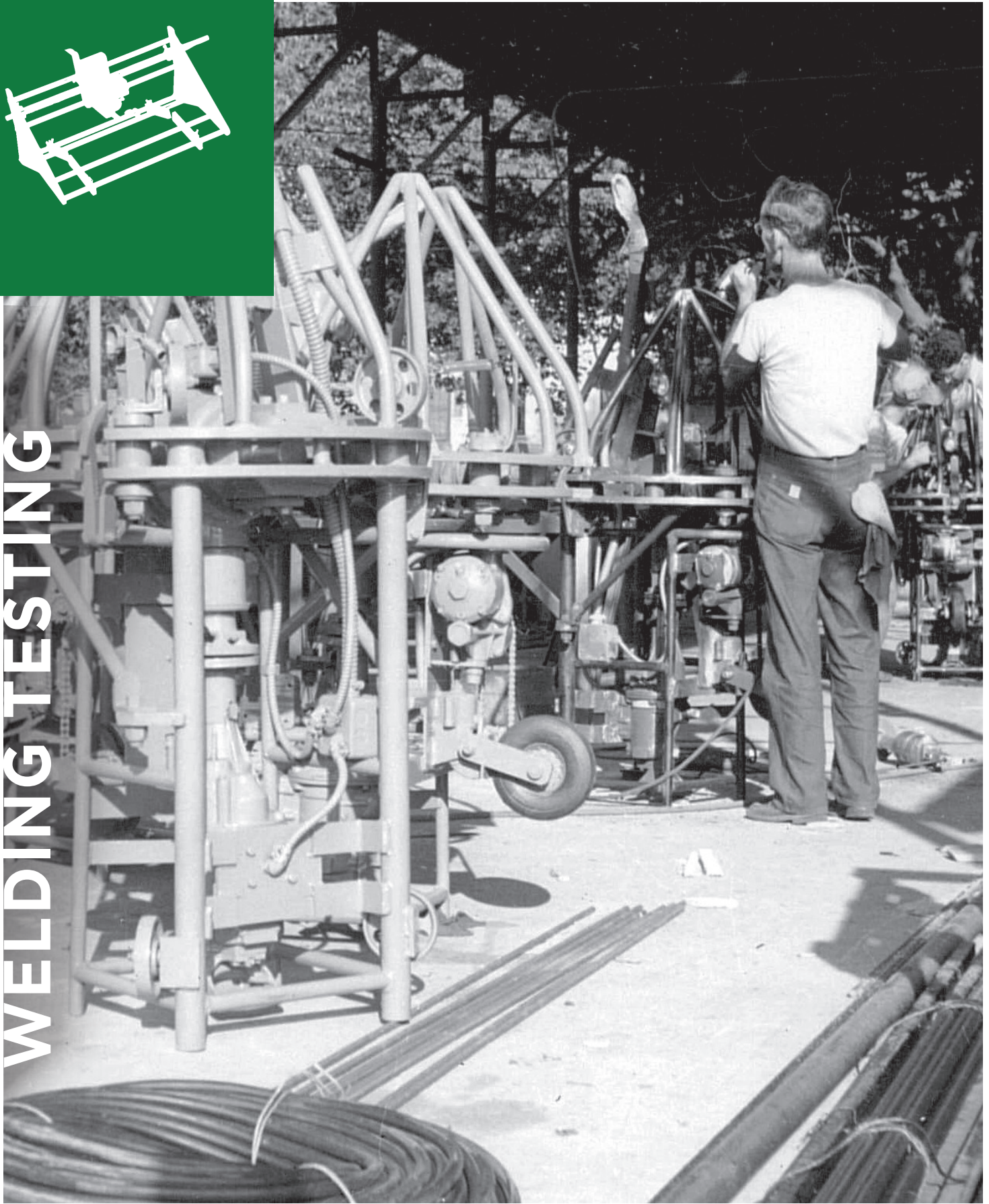

On Coupon Cutters:

“Due to the increased requirement for machine cut straps, you can’t beat this machine in its value and simplicity.”

~JT Distributor, OK

Guided 15-ton Strap Bender

The most portable solution

- For weld Coupon Testing
- Horizontal or vertical use

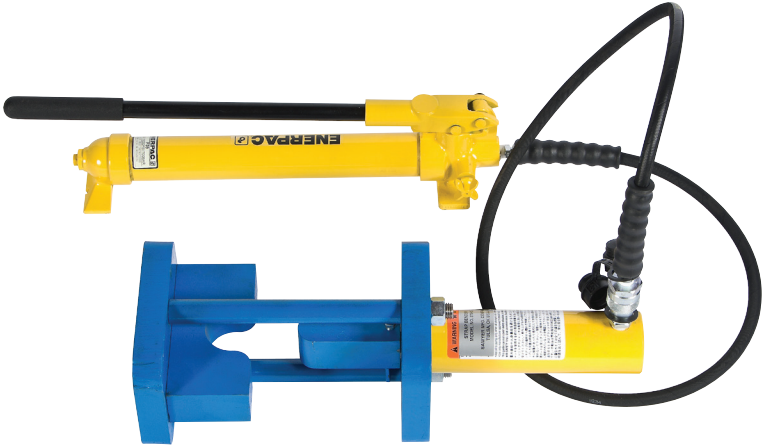

Model 273-15

OPTIONAL ACCESSORIES

Electric Pump

Test and qualify your welders with the push of a button



Foot Pump

*Swift controlled pneumatic operation**



* Access to air compressor is necessary for foot pump operation.

Guided 25/50-ton Bend and Tensile Tester

For accurate Weld-Quality Testing



Model 273-25

- Both guided bend and tensile strength testing
- Includes liquid filled, certified gauge with high level indicator, 2 speed manual pump (1) die and plunger, (1) set of pulling jaws, and (1) steel carrying case

OPTIONAL ACCESSORIES

Electric Pump

Test and qualify your welders with the push of a button



Foot Pump

*Swift controlled pneumatic operation**



* Access to air compressor is necessary for foot pump operation.

Coupon Cutter

Cut straps consistently and efficiently

- From 3"—14"
- Speed: 6 turns per inch travel
- Left or right hand operation

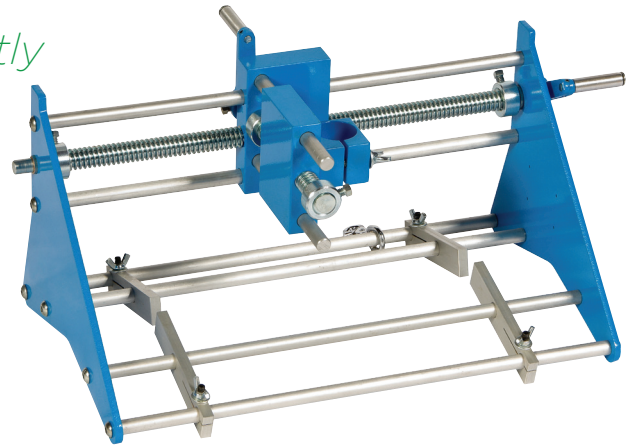

Model 270D

CYLINDERS & CUSTOM MACHINING

Hydraulic Cylinders

Custom built for heavy equipment

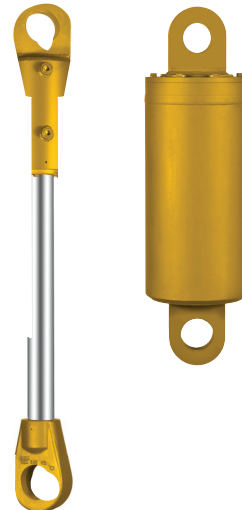

Custom Machining

Custom built for your needs

Please call 877-730-9149 or email info@sawyermfg.com for information on our hydraulic cylinders or for a quote on your custom machining needs.

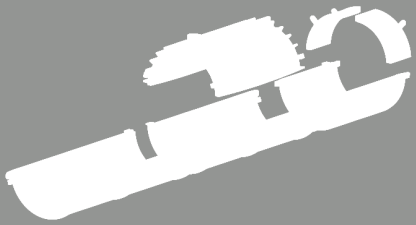

PIPE BENDING



On Bending Dies:

"Most Folks don't realize 99% of American Pipe Bending dies go through Sawyer Manufacturing."

Tractor Bending Shoes

Versatile and rugged

- Available for pipe sizes 3”–16”
- All Bending Shoe sizes work on the same adapter

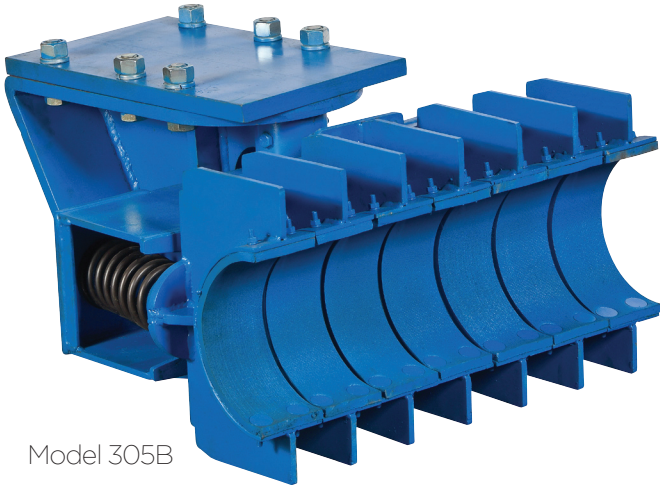

Model 305B

*Tractor Bending Shoe Mount (which includes adapter, pins and springs) sold separately - Part 4AR

Pipe Bending Sets

Check to see if it says Sawyer inside

- 20” sets come in 3 pieces with a Die, Stiffback, and Pinup Shoe
- 30” and larger sets come in 6 pieces with a Die, Stiffback, (2 pieces), Pinup Shoe, and Pinup Clamp (2 pieces)
- Sets are made for any make, model, and size of Pipe Bending Machine

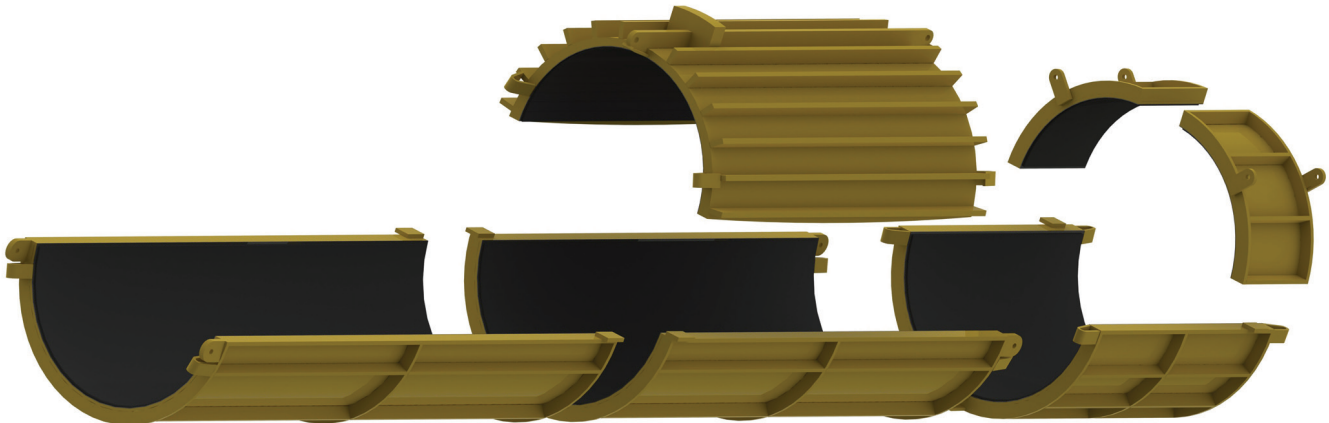



Designed *and* Manufactured
BY
SAWYER-JENSEN CO.

QUALITY HERITAGE TRADITION

Sawyer Manufacturing Company
7799 South Regency Drive
Tulsa, Oklahoma 74131
P (918) 834-2550
F (918) 834-0318

 facebook.com/SawyerMFGco  youtube.com/SawyerMFG
 twitter.com/SawyerMFG  linkedin.com/company/sawyer-mfg-company